



Installation guide

Brake motors
FFB

Reference: 5286 en - 2015.04 / a

Leroy-SomerTM

This document complements general manual ref. 1889 (recommendations), ref. 4850 (LSES motor), ref. 4155 (LSRPM motor), and specific manual ref. 5287 (FFB brake maintenance).

FFB brake motors are units consisting of an induction motor and a failsafe braking system (safety brake).

This brake motor benefits from the experience of one of the largest manufacturers in the world, using state-of-the-art technology in automation, specially selected materials and rigorous quality control. As a result, the regulatory authorities have awarded our motor factories the ISO 9001 - Edition 2008 international certificate.

These symbols appear in this document whenever it is important to take special precautions during installation, operation, maintenance or servicing of the brake motors.



General danger



Electrical hazard



Risk of physical injury



These recommendations, instructions and descriptions refer to standard use. They do not take account of non-standard versions or special adaptations. Failure to comply with these recommendations can lead to premature wear and tear of the motor and can invalidate the manufacturer warranty.

Make sure that the brake motor is compatible with its environment before its installation and also throughout its life.



The following preliminary precautions must be taken before working on any stationary device:

- **Mains voltage disconnected and no residual voltage present**
- **Careful examination of the causes of the stoppage** (blocked transmission - loss of phase - cut-out due to thermal protection - lack of lubrication, etc.)



Electric brake motors are industrial products. They must therefore be installed by qualified, experienced and authorized personnel. The safety of people, animals and property must be ensured when fitting the motors into machines (please refer to current standards).

Particular attention must be given to equipotential ground or earthing connections.



Safety of personnel: Protect all rotating devices before power-up. If a brake motor is started up without a coupling device having been fitted, carefully immobilize the key in its location. All measures must be taken to ensure protection against the risks which arise when there are rotating parts (coupling sleeve, pulley, belt, fan, etc.). Personal protective equipment must be worn. After work is carried out, the lids of the terminal box and its cover must always be closed.



Beware of backdriving:

- When the motor is switched off. The appropriate precautions must be taken: for example, for pumps a non-return valve must be installed.



- When the brake motor is fitted with an active brake release lock off system (DLM), **it is vital to ensure safety (of people and property) in exposed areas.**

Before any intervention on the brake, check that it holds no load.



- After an operating period, certain parts of the brake motor may be hot and are likely to cause burns.

1 - RECEIPT	14
1.1 - Identification	14
1.2 - Storage	14
2 - RECOMMENDATIONS	14
2.1 - Commissioning	14
2.2 - Mechanical installation.....	14
2.2.1 - Brake with options	15
2.3 - Electrical connection.....	15
2.3.1 - Terminal box	16
2.3.2 - Optional cable gland.....	16
2.4 - Wiring diagrams.....	16
2.4.1 - Motor	16
2.4.2 - Brake coil.....	17
2.4.3 - Encoders	17
2.4.4 - Forced ventilation unit	18
2.4.5 - Options.....	18
3 - REGULAR SERVICING	19
4 - PREVENTIVE MAINTENANCE.....	20

en

LEROY-SOMER reserves the right to modify the characteristics of its products at any time in order to incorporate the latest technological developments. The information contained in this document is therefore liable to be changed without notice.

1 - RECEIPT

Check the state of the brake motor; if there is any damage to the motor or even its packaging, inform the carrier.
Check that the brake motor conforms to the order (mounting arrangement, information on the nameplates).

1.1 - Identification

Motor nameplate

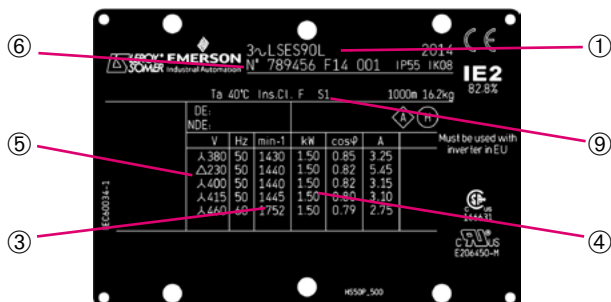

Brake nameplate

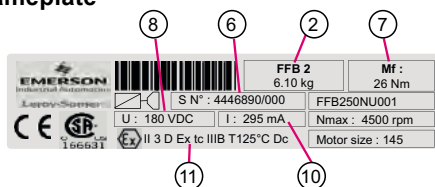

Essential information included on the nameplates:

①	Motor series, frame size
②	FFB brake type <input checked="" type="checkbox"/> <input type="checkbox"/>
③	Speed of rotation (rpm)
④	Rated power (kW)
⑤	Motor voltage (V)
⑥	Motor and brake manufacturing no.
⑦	Mf: Braking torque (N.m)
⑧	U: Brake coil voltage (VDC)
⑨	Duty - Duty (operating) factor
⑩	I: Coil current (mA)
⑪	Specific (ATEX) marking

Information to be remembered for spare parts orders

Definition of symbols

T: Impregnation index

IE2: Efficiency class

IP-- IK--: Index of protection*

Ins. Cl.F: Insulation class

(Ta) 40°C: Ambient operating temperature

cos P or φ: Power factor

A: Rated current

Δ: Delta connection

λ: Star connection

*IK: Shock resistance

The motor can withstand a weak mechanical shock (IK 08 according to EN 50102). **The user must provide additional protection if there is a high risk of mechanical shock.**

Bearings

DE: Drive end bearing

NDE: Non drive end bearing

Marking

CE: Legal mark of conformity of product to the requirements of European Directives

UL: CSA certified product, UL conformity

1.2 - Storage

Store the equipment in a clean, dry location, protected from shocks, vibrations, variations in temperature and in an environment with relative humidity of less than 90%.

Storage for longer than 6 months leads to special conditions, we will be happy to discuss these with you.

After storage for a period of more than 6 months, disconnect the brake power supply unit and check the winding insulation resistance (phase/earth resistance higher than 10 MΩ). Drain any condensation water.

2 - RECOMMENDATIONS

2.1 - Commissioning

The brake motor is designed to operate at the speeds indicated on the nameplate (do not exceed the maximum speeds stated in our technical catalogues).

Comply with the voltages and frequencies indicated on the nameplate (do not deviate by more than 5% from the voltage extremes on the nameplate and by more than 1% from the frequencies).

For hoisting applications, do not use a motor that is not rated S3 (except for variable speed). Do not use a motor with a different duty type from that on the nameplate no. ⑨.

2.2 - Mechanical installation

(Also see manual 1889)

If the brake motor has been stored at a temperature lower than -10°C, heat it and turn the shaft manually before starting up the machine.

If the brake motor is to be used at a temperature lower than -25°C, it must not be fitted with a sensor. It can be fitted with thermocouples.

Ensure there is minimum clearance (corresponding to the length of the cover) at the non-drive end of the brake motor so it can be put down (inspections and brake adjustments).

Install the brake motor in conditions conforming to those on the order (temperature, relative humidity, altitude).

When the brake motor is fitted with lifting rings, these are for lifting the brake motor on its own (tighten the ring, if necessary, before handling).

Mount the brake motor in the position specified on the order, on a flat, rigid base in order to prevent distortion and vibration. Ensure the fixing screws are tightened to the correct tightening torque (class 8.8 minimum according to ISO 898-1), the screw diameter must be the right size for the fixing holes.

Ensure the mechanical shafts are aligned and the coupling and pulley are mounted in accordance with good practice.

Do not knock the motor (terminal box, cover), the shaft or the coupling during mounting, do not crush the seal, do not project beyond the shoulder of the shaft.

Ensure correct brake motor cooling, the air intakes and outlets must be kept clear.

Check that the loads applied to the motor shaft (especially the belt tension) are compatible with the values stated in our technical catalogues.

2.2.1 - Brake with options

- Auto-return hand brake release (DLRA)

For brakes fitted with a lever, push it towards the back of the brake motor.

Whenever the brake has been released, make sure that it is engaged once any maintenance operations have been completed.

See dismantling/reassembly procedure in ref.5287 FFB maintenance.

- (Manual) brake release lock off system (DLM)

For brakes fitted with a DLM, proceed in the same way as the DLRA to release the brake and then turn (clockwise) the DLM handle in line with the DLRA to lock the brake in the released position. When the brake is next powered up, it is engaged automatically and the brake is operational again.

See dismantling/reassembly procedure in ref.5287 FFB maintenance.

- Remote (electrical) brake release lock off (DMD)

For brakes fitted with a DMD, supply the brake coil with power separately from the motor. Once the brake is released, supply the electromagnet on the lock control board with power. Once the locking contactor is engaged, switch off the brake coil power supply and then that of the control board. The brake is held in the released position. When the brake is next powered up, it is engaged automatically and the brake is operational again.



Whenever the brake has been released, make sure that it is engaged.

- Release indicator (open/close)

For brakes fitted with a release indicator, while the brake is supplied with power the armature actuates a microswitch (discrete) fixed on the backplate indicating brake release. When the power is switched off, the microswitch changes state in order to confirm that the brake is engaged.

- Wear indicator

For brakes fitted with a wear indicator, while the brake is supplied with power the armature actuates a microswitch (discrete) fixed on the yoke. If the brake lining is worn (+ 0.6 mm) the microswitch is actuated and informs the user of the need to adjust the air gap or change the brake lining if it is less than the required minimum (See the "Adjusting the air gap" procedure in ref.5287 FFB maintenance).

2.3 - Electrical connection



The cables should be connected with the power off by qualified personnel, in accordance with good practice, in compliance with the safety conditions. Choose the protection system and cables according to the information on the nameplate (the voltage drop during the starting phase must be less than 3%).

Tighten the terminal lock nuts, connectors and power supply cables to the torque stated below (N.m):

Terminal	M4	M5	M6	M8
Steel	1	2.5	4	10

If using cables without connectors, attach calipers.

- Do not place washers or lock nuts between the motor connections and the connections on the power supply cable. Connect the thermal protection devices and accessories (section 2.4.5).

Ensure that the cable gland is watertight (the cable gland must always correspond to the diameter of the cable used).

Incorporate a bend where the cable enters the terminal box to prevent water entering via the cable gland.

Check the motor direction of rotation (section 2.4.1).

The internal terminal box connections must never be put under any stress due to the cables connected by the user.

Earthing

It is mandatory to earth the brake motor (in the terminal box and on the brake), and earthing must be performed in accordance with current regulations (protection of workers).

Power supply (see wiring diagrams under the terminal box cover, section 2.4).

Brake motors with a built-in power supply are connected like standard motors. They are fitted with a DC coil (180 VDC). The brake is supplied directly from the motor stator (230/380/400/415/460/480 V) via a brake power supply unit, rectifier mounted in the terminal box.

For motors with different voltages, starting at reduced voltage or operating at variable voltage or frequency, a separate brake power supply must be provided. (The same applies to a 20 VDC coil).

To reduce the brake application response time (mandatory in Hoisting applications), it is necessary to switch off the brake DC power supply at the same time as that of the motor, usually via an auxiliary contact on the motor starting contactor.

2.3.1 - Terminal box (TB) of FFB brake motors

The standard terminal box of the FFB brake motor has holes on sides 1 and 3:

- frame size 71 to 132 S, SU: 4 x ISO M20x1.5
- frame size 132 SM, M, MU and 160: 2 x ISO M25x1.5 and 2x ISO M20x1.5

These holes are closed with threaded plugs. An optional cable gland kit is available, otherwise procure the necessary cable glands in accordance with the table below:

	1-speed	2-speed		accessories	
	DOL starting, YΔ	1 Dahlander wdg	2 wdgs 1 voltage	2 wdgs 2 voltages	1 or 2 ¹
LS 71	1 ISO 20a	2 ISO 20a		1 ISO 20a + 1 ISO 12	
(F*)LS(ES) 80 ->132S, SU	1 ISO 20	2 ISO 20			
(F*)LS(ES)ES 132M, MU	1 ISO 25	10/03/15			
(F*)LS(ES) 160	2 ISO 25	2 ISO 25			

*FLS: Add an ISO 12 on side 4 for brake connection in the terminal box
 1 or 2¹: one ISO 20a per option: separate power supply, sensors, resistors, DMD, etc.
 > 2²: one ISO per option: sensor, indicator lamps, etc.

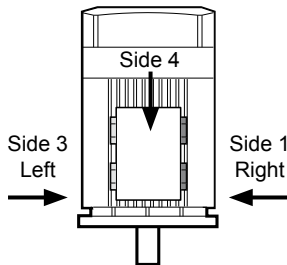

2.3.2 - Optional cable gland (PE)

The cable sizes below are given for guidance only; follow the supplier's instructions.

LS(ES) series
Polyamide cable gland

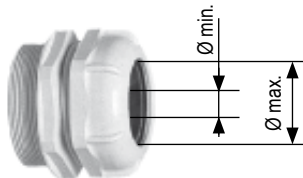

Cable gland type	Standard cable gland (polyamide)		
	Cable size		Tightening torque Gland and body (N.m)
	Min. cable Ø (mm)	Max. cable Ø (mm)	
ISO 20a	5	12	2
ISO 20	7	14	2
ISO 25	9	18	3

FLS(ES) series
Brass anchoring cable gland

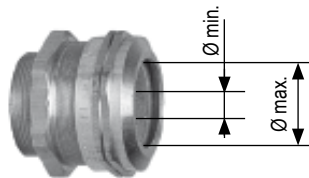

Cable gland type	Brass anchoring cable gland		
	Cable size		Tightening torque Gland and body (N.m)
	Min. cable Ø (mm)	Max. cable Ø (mm)	
ISO 20a	6	10	4
ISO 20	8	12	4
ISO 25	11.5	18	6

The terminal box is watertight once the cable glands have been fitted and each cable gland is tightened on the cable according to its cable size.

Adapt the cable gland and its reducer if present to the diameter of the cable being used.

In order to maintain the brake motor's original IP55 protection, it is essential to ensure the cable gland provides a total seal by tightening it correctly (so that it cannot be unscrewed by hand).

When there are several cable glands and some are not being used, ensure that they are always covered (threaded plugs) and tighten them so that they also cannot be unscrewed by hand.

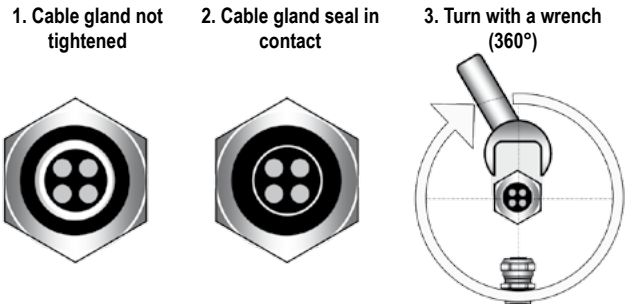

2.4 - Wiring diagrams

2.4.1 - Motor



Check the motor direction of rotation.

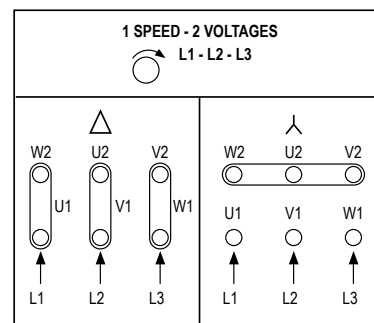
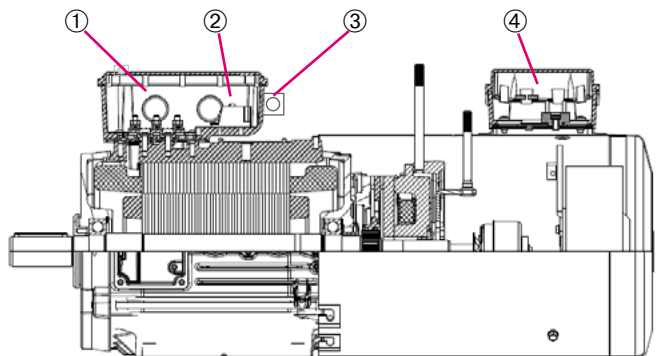
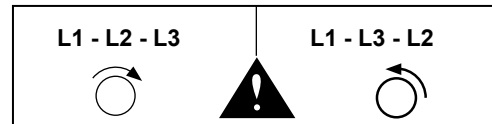

① and ② Brake motor: wiring diagram under the TB cover

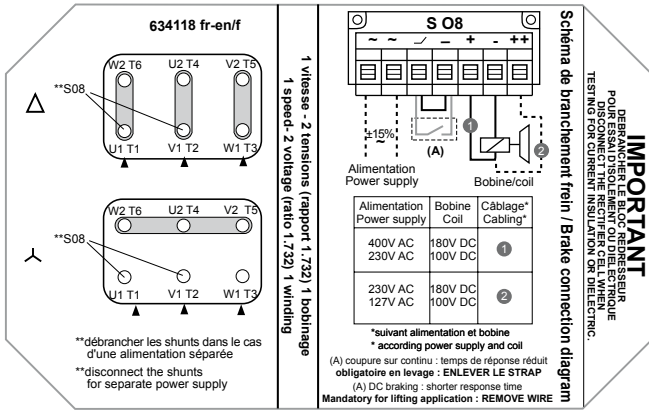

Check the brake wiring according to the power supply

2.4.2 - 180 VDC brake coil

Alimentation Power supply	Bobine Coil	Câblage* Cabling*
400V AC 230V AC	180V DC 100V DC	①
230V AC 127V AC	180V DC 100V DC	②

*suivant alimentation et bobine
 * according power supply and coil

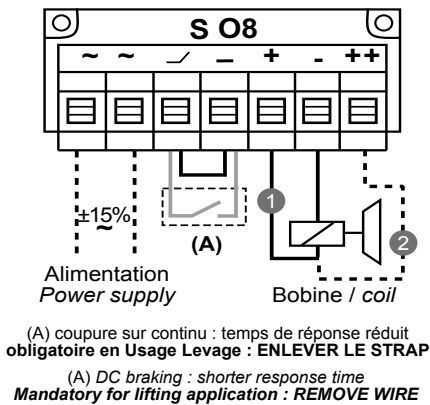

② 20 VDC brake coil:

Wiring diagram for the separate 24 V power supply option (frame sizes 71 to 160)

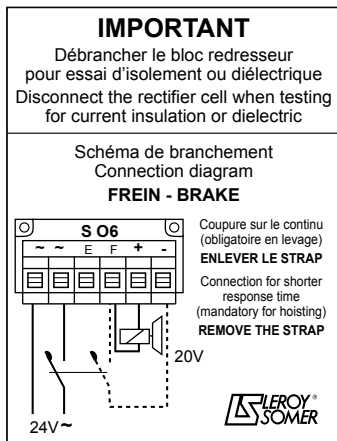

② 180 VDC brake coil:

2-speed motor, 2 windings, 1 voltage, built-in power supply

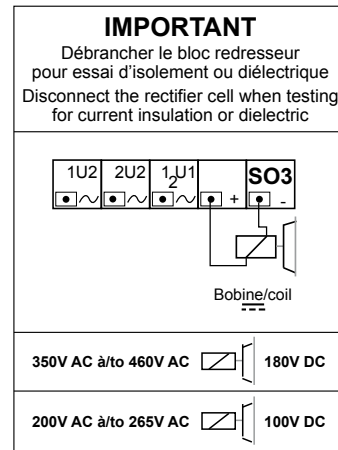

2.4.3 - Encoders

③ Standard incremental encoder: 5 VDC 1024 (or 4096) rev - Brake with separate power supply

Terminal No.	
1	0V
2	+VDC
3	A
4	B
5	0
6	A
7	B
8	0
9	NC
10	NC
11	NC
12	NC



View of male connector base at the encoder end

NC: Not Connected (free)

③ Standard absolute encoder: SSI 10/30 VDC, 4096 rev - Brake with separate power supply (ex. supplier)

Pin layout
 17-pin HEIDENHAIN coupling

Power supply				Incremental signals				Other signals		
7	1	10	4	11	15	16	12	13	3	2
Up	Sensor Up	0V	Sensor 0V	Internal shield	A+	A-	B+	B-	Vacant	Vacant
Brown/ Green	Blue	White/ Green	White	/	Green/ Black	Yellow/ Black	Blue/ Black	Red/ Black	Red	Black

Absolute position values					
14	17	8	9	5	6
DATA	DATA	CLOCK	CLOCK	Vacant	Vacant
Gray	Pink	Violet	Yellow	Green	Brown

Shield on housing. Up = power supply voltage
 Sensor: The sensor line is connected internally with the corresponding power line.
 Vacant pins or wires must not be used!



- Switch off the power supply before performing any connection operations (connection or disconnection, with or without connectors) at the encoder or cabinet end.

- For reasons of synchronization, power up and power down the encoders and any associated electronic devices simultaneously. On the first power-up, check that the "supply +" terminal is supplying the required voltage before connection.

- For the supply, use stabilized power supplies. Power supplies via transformers providing 5 V (or 24 V) rms, followed by rectifiers and smoothing capacitors, must not be used, as in reality the resulting DC voltages obtained are:
 For 5 V: $5 \times \sqrt{2} = 7.07$ V
 For 24 V: $24 \times \sqrt{2} = 33.936$ V

- Removable connector

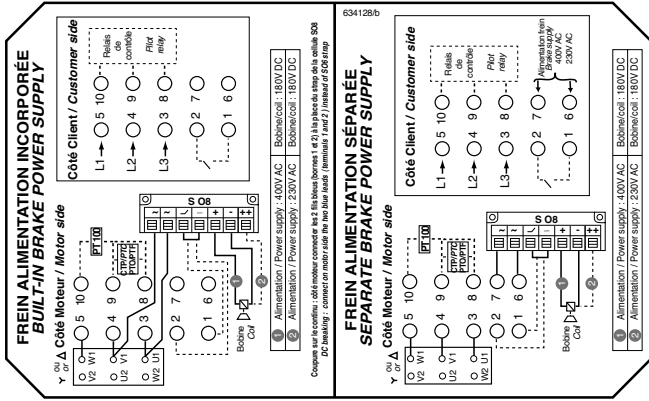

Wiring diagram for Reduced response time option - Built-in power supply mandatory

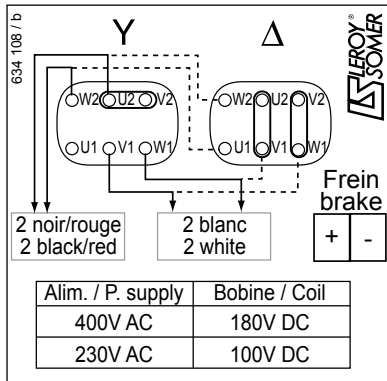

2.4.4 - 230 V or 400 V forced ventilation unit for frame size ≤ 160

LS 71

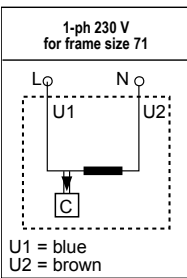

(F)LS(ES) 80 to 132

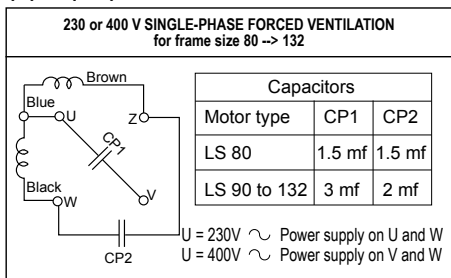

(F)LS(ES) 160

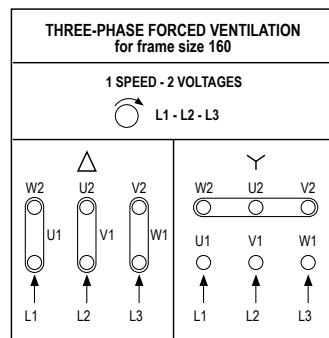

2.4.5 - Options

- Thermal protection

Standard thermal protection Class F, 150°C		
	Double PTO	Triple PTC
Breaking current	1.6 A - cos φ 0.6	-
rms voltage	250 V	2.5 V max
Mounting	on clamp terminal + flag (purple/white)	on terminal block (except frame size 71: on clamp terminal) + flag (black/black)
Heat sensors		
	PT100	KTY
Measuring current	10 mA max	10 mA max
rms voltage	-	-
Mounting	on clamp terminal (3 wires - black/red/black)	on clamp terminal (brown/white)
Indicators		
	Release indicator (Open/Close)	Wear indicator
Current	6 A	6 A
Voltage	250 V	250 V
Mounting	on clamp terminal (3 wires - blue/black/gray) Black/Blue = NO Black/Gray = NC	on clamp terminal (3 wires - blue/black/gray) Black/Blue = NO Black/Gray = NC

NO: normally opened; NC: normally closed

- VARMECA 31/32 with ESFR

(Also see VMA manual ref. 3776)

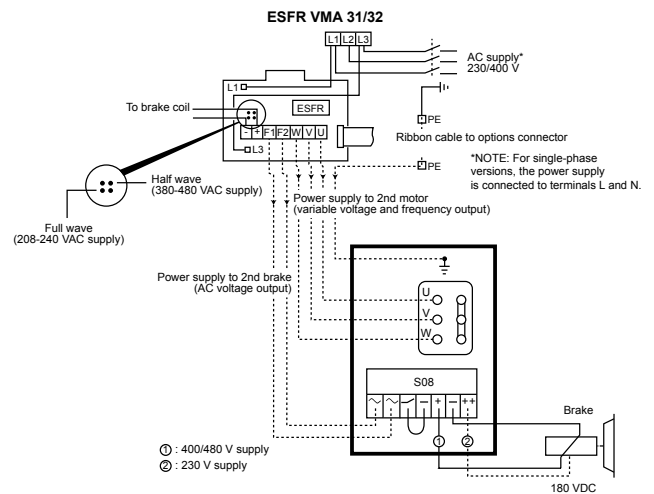

- VARMECA 33/34 with ESFR

(Also see VMA manual ref. 3776)

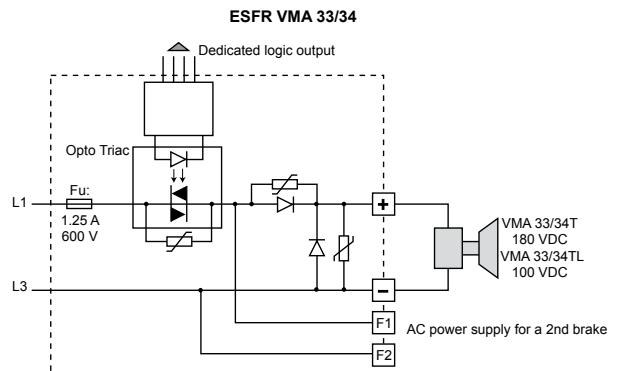

3 - REGULAR SERVICING

Checks after start-up

After approximately 50 hours' operation, check that the screws fixing the motor and the coupling device are still tight. In the case of chain or belt transmission, check that the tension is correctly adjusted. Check the electrical connections. Check the vibrations. Check that there is no abnormal noise. If the brake wear needs to be checked: measure the air gap to check that it conforms to the maximum authorized dimension. (See the "Adjusting the air gap" procedure in section 4.4 ref. 5287 FFB maintenance)

Annually

Perform the checks indicated above.

Cleaning

Precautions to be taken: before carrying out any cleaning operation, check that the brake motor is totally sealed (terminal box, drain holes, etc).

Dry cleaning (vacuuming or compressed air) is always preferable to wet cleaning.

To ensure the brake motor operates correctly, remove any dust or foreign bodies that might **clog the brake moving parts**, the cover grille and the housing fins.



Always clean at reduced pressure from the center of the brake motor outwards to avoid introducing dust and particles under the seals.

Draining condensation water

Temperature variations cause condensation to form inside the motor, which must be removed before it adversely affects motor operation.

Condensation drain holes, located at the bottom of the motors (bearing in mind their operating position) are sealed with plugs that must be removed and then replaced every six months (if they were not replaced, the motor degree of protection would no longer be maintained). Clean the orifices and plugs before reassembling them.

Note: In conditions of high humidity and significant temperature variations, a shorter period is recommended.

When there is no risk to the motor protection, the condensation drain plugs can be removed.

4 - PREVENTIVE MAINTENANCE

Consult Leroy-Somer (www.leroy-somer.com: Services/Drive systems) who in its continuous search for ways to help our customers, has evaluated numerous methods of preventive maintenance.

The diagram and table below give the recommended equipment to use and the ideal positions to take measurements of all parameters that can affect the operation of the machine, such as eccentricity, vibration, state of the bearings, structural problems, electrical problems, etc.

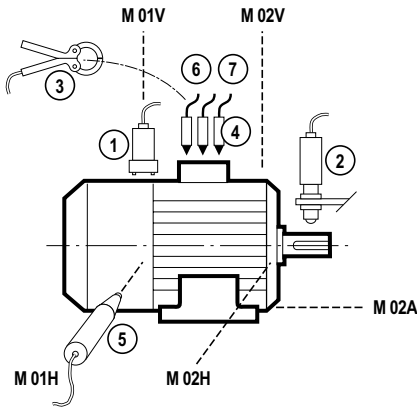

Detector	Measurement	Measurement points												
		M01V	M01H	M02V	M02H	M02A	Shaft	E01	E02	E03	E04	E05		
①	Accelerometer	For measuring vibrations	X	X	X	X	X							
②	Photo-electric cell	For measuring speed and phase (balancing)							X					
③	Clamp ammeter	For measuring current (D.C. and 3-phase A.C.)								X	X	X		
④	Multimeter	For measuring voltages								X	X	X		
⑤	Infra-red probe	For measuring temperature	X		X									
⑥	Megohmmeter	For measuring insulation resistance				X				X				
⑦	Ohmmeter	For measuring the coil resistance								X	X	X	X	X

Before conducting any work or preventive or corrective maintenance operations, please consult: www.leroy-somer.com, manual ref. 5287 FFB maintenance.



EMERSON[™]
Industrial Automation

Leroy-Somer[™]