

# **Solbrake** (SMB)

---

**Electronic Motor Brake (DC Injection)**

**8 - 390A, 220 - 690V**

**Instruction Manual**

Ver.11.0/11. 2002

# Table of Contents

Page	Subject
3	Brake selection
4	Installation Notes
5	Mode of operation
6-7	Wiring and operation
8	Potentiometer settings and Start up procedure
9	Fuse Selection Table
10	Dimensions
11	Technical Specification



- \* Read this manual carefully before operating the equipment and follow its instructions
- \* Installation, operation and maintenance should be in strict accordance with this manual, national codes and good practice. Installation or operation not performed in strict accordance with these instructions will void manufacturer's warranty.
- \* Disconnect all power inputs before servicing the Solbrake / SMB and/or the motor.
- \* After installation, check and verify that no parts (bolts, washers, etc) have fallen into the power Section (IP00).

## ATTENTION

1. This product was designed and tested for compliance with IEC947-4-2 for class A equipment.
2. The Solbrake / SMB brakes are designed to meet UL requirements
3. Use of the product in domestic environments may cause radio interference, in which case the user may be required to employ additional mitigation methods.
4. Utilization category is AC-53a or AC53b. Form1.
5. For further information see Technical Specification



## WARNING

- \* Internal components and P.C.B's are at mains potential when the Solbrake / SMB is connected to mains.  
This voltage is extremely dangerous and may cause death or severe injury if contacted.
- \* When the Solbrake / SMB is connected to mains, even if operation signal is disconnected full voltage may appear on Solbrake / SMB's output.
- \* Unit must be grounded to ensure correct operation, safety and to prevent damage.
- \* Check that Power Factor capacitors are not connected to the output side of the Solbrake / SMB.

# Brake Selection

## General

The Solbrake / SMB - Solid State Motor Brake provides fast, smooth, frictionless braking of three-phase squirrel-cage motors by injecting controlled DC current to the motor windings, after Mains contactor opened. This induces a stationary magnetic field, which exerts a braking torque on the rotor.

Stopping time can be similar to the time it takes to reach full speed on a Direct-On-Line starting.

Adjustable Braking Torque and Braking Time enable perfect matching of the brake to the driven load.

Automatic sensing System turns the brake off automatically when the motor comes to a full stop. This minimizes the motor heating.

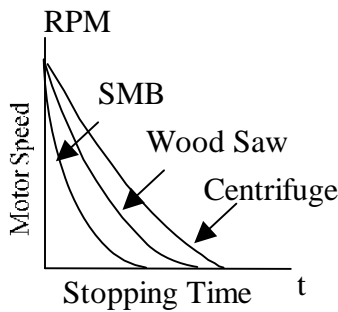

## Brakes ratings and Frame sizes

Max Motor FLA (Amp)	Brake Type FLC	Frame Size	Case material
10	Solbrake 10	SB0	PC/ABS
17	Solbrake 17	SB1	Aluminum
31	Solbrake 31		
58	Solbrake 58		
105	Solbrake 105	SB2	Metal
170	Solbrake 170		
210	Solbrake 210		
310	Solbrake 310	SB3	
390	Solbrake 390		

## Dimensions (mm)

Size	Width	Height	Depth
SB0	45	75	105
SB1	65	190	114
SB2	154	280	160
SB3	224	384	222

Select the brake according to the following criteria:

## Motor Current & starting conditions

- Motor's Full Load Ampere (FLA) - as indicated on its nameplate (even if the motor is not fully loaded).
- The Solbrake (SMB) is designed for a duty cycle of 10% or less; e.g. 10 sec. operation, 90 sec. rest.

Duty Cycle - the ratio between operating time and total cycle time (rest time + Braking time).

$$\text{Duty Cycle} = \frac{\text{Braking time}}{\text{Rest time} + \text{Braking time}} \times 100 (\%)$$

## Note:

If a higher duty cycle is required select a higher Solbrake (SMB) type to allow enough brake time current.

## Mains Voltage (line to line)

Thyristor's PIV rating, internal circuitry and insulation determines six voltage levels: Each brake is factory set for one of the following levels according to the Ordering Information.

Voltage	Tolerance
220- 240 V	+10 -15 %
380 - 415 V	+10 -15 %
440 V	+10 -15 %
460 - 500 V	+10 -15 %
575 - 600 V	+10 -15 %
690 V (210A-390A)	+10 -15 %

Each brake is factory set for one of the above levels and suitable for 50 or for 60 Hz ( $\pm 5\%$ ).

## Options (see Ordering Information)

For extended braking time - consult factory and provide the following information:

- Ambient temperature.
- Actual stopping current.
- Actual stopping time.
- Time interval between starts
- Load characteristics

## Installation Notes

### Prior to Installation

Check that Motor's Full Load Ampere (FLA) is lower than or equal to Solbrake / SMB Full Load Current (FLC) and verify that Mains voltage and frequency are as indicated on the Solbrake / SMB label.

### Mounting

- \* The Solbrake / SMB must be mounted vertically, allow space above and below the unit for sufficient airflow.
- \* It is recommended to mount the SMB directly on the rear metal plate for better heat dissipation.
- \* Do not mount the Solbrake / SMB near heat sources.
- \* Protect the Solbrake / SMB from dust and corrosive atmosphere.

### Temp. Range and Heat Dissipation

The Solbrake / SMB is rated to operate over a temperature range of  $-10^{\circ}\text{C}$  ( $14^{\circ}\text{F}$ ) to  $+50^{\circ}\text{C}$  ( $122^{\circ}\text{F}$ ).

Relative non-condensed humidity inside the enclosure should not exceed 93%.

The average heat dissipation of the Solbrake / SMB depends on the Braking Torque setting and on the duty cycle.

Heating inside the enclosure can be reduced through the use of additional ventilation.

**Note:** The heat generated in the motor during braking is similar to the heat generated during starting. Therefore, high setting of the Braking Torque and/or a high duty cycle may require an external cooling fan for the motor. It is recommended to use temperature sensor in the motor which will allow restarting only after the motor temperature has reduced to an allowed level.

### Short Circuit Protection

The Solbrake / SMB must be protected against short circuit by fast-acting fuses. Recommended  $I^2t$  values in page 9.

### Transient Protection

Line transient voltages can cause malfunctioning of the brake and damage to the SCRs.

When high transients are expected, an external protection should be used, (consult factory).

### Wiring

Connections to  $L_1$ ,  $L_2$ , U, V and W should be done with power cables. Connections to terminals 1-6 are for control only.

Do not connect two Solbrake / SMB brakes in parallel as they are not synchronized and will be damaged.

Mechanical and electrical interlock between Mains contactor  $C_1$  and braking contactor  $C_2$  must be installed to prevent both contactors from being closed simultaneously.

### Solbrake / SMB Wiring

The Solbrake / SMB (10-17) are meant for installation on a Din-Rail. See options list for other Din-Rail ratings.

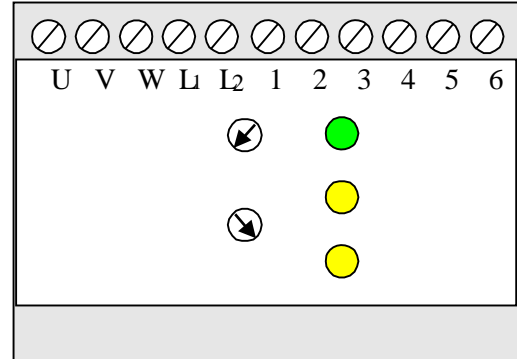

### Power Factor Capacitors

Power factor correction capacitors must not be installed on the load side of the Solbrake / SMB. When required, capacitors should be installed on the Solbrake / SMB's line side.

#### Notes:

1. The Solbrake / SMB uses Mains power to produce the braking torque. Therefore, a power failure or disconnection will disable the DC braking and the motor will coast to a stop without braking.
2. When required to stop a motor during a power outage, an electro-mechanical brake must be used.
3. The Solbrake / SMB cannot be used for continuous holding of loads, after motor had stopped. An electro-mechanical brake should be used for holding at stop position.

### Warning

Wrong connections of Solbrake line and load sides will cause damage to the brake and motor.

# Mode of Operation

Stop signal opens motor contactor  $C_1$  that in turn initiates the closing of brake contacts  $C_2$ .

The Thyristor is switched on and fire (to inject DC current to the motor) after time delay, to induce the braking current.

The torque, which is a function of the DC current, can be controlled by the firing angle of the Thyristor.

**Note:** there is a time delay between opening of one contactor and closing the other one to reduce the EMF. The time delay correlate to the size of the motor.

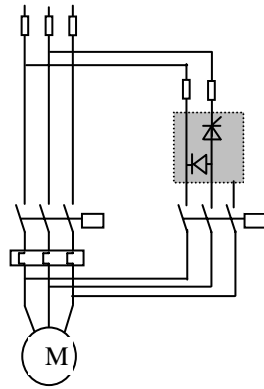

The Solbrake / SMB incorporates the following built-in time delays:

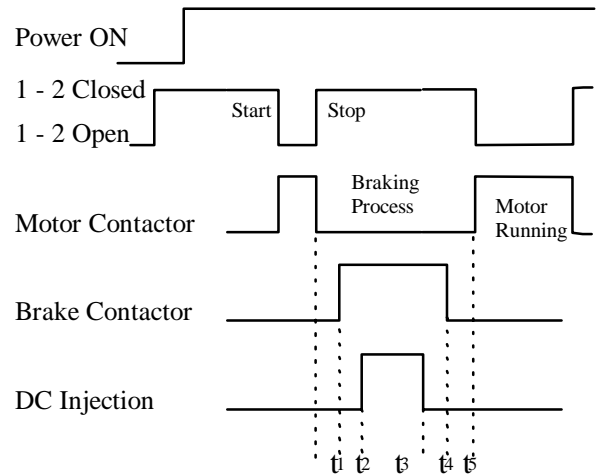

## Braking Time

Braking time depends on the inertia, friction of the load, speed, and braking current. The required braking time is best established by practical experience.

The Solbrake / SMB offers two operating modes, Automatic and Manual. Selection between the modes is done by an internal dip switch.

Dip sw.	Operation Mode
On	Manual
Off	Automatic

It is recommended to use the Automatic mode (factory default setting) to reduce the braking time and minimize motor heating.

## Automatic operation

DC injection duration is automatically controlled by the Solbrake / SMB. Injection ceases when Motor has come to a complete stop.

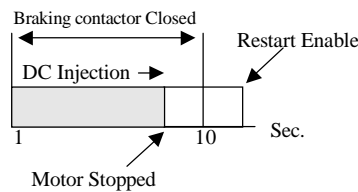

## Manual operation

DC injection duration is according to the Braking Time setting on the front panel.

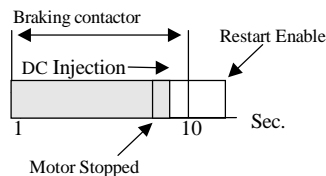

## Notes:

- Motor heating during braking is similar to heating during Direct On Line starting. Therefore, always adjust for the shortest DC injection time duration.
- In general, for improved braking process to be in effect, it is recommended to apply some minimal inertia on the motor shaft.

Where:

- $t_1$  - Time delay between opening of motor's contactor  $C_1$  and closing of brake contactor  $C_2$ , allowing motor's back EMF to diminish (see table below).
- $t_2$  - Time delay of 0.05 sec between closing of brake contactor  $C_2$  and initiation of DC current, to ensure that brake contactor does not switch DC current, enabling the use of regular AC contactor.
- $t_3$  - In Auto Mode – Enabling of DC current injection. In Manual Mode - time of DC current injection. Range: 1-10 sec.
- $t_4$  - Time delay between end of DC current injection and opening of brake contactor  $C_2$  to ensure that the contactor does not switch DC current, enabling the use of regular AC contactor (see table below).
- $t_5$  - Time delay of 0.2 sec. between opening of brake contactor  $C_2$  and enabling motor's restart.

## Approximate Time Delays (sec).

Solbrake / SMB	8	17	58	105	210	390
$t_1$	0.2	0.3	0.6	1.1	1.7	2.5
$t_4$	0.2	0.2	0.3	0.8	1.2	1.9

## Torque at standstill

When required to maintain the DC braking current after the motor has come to a complete stop, set Auto/Man Dip Switch to On (Manual operation). Set Braking Time to a longer time than it takes the motor to come to a complete stop.

**Note** - DC Injection after motor has come to a complete stop may cause excessive heating of both the motor and the brake.

# Wiring & Operation

## Solbrake / SMB with Direct on Line Starter

Motor contactor  $C_1$  (with one N.O + two N.C contacts).

- \* Contact  $C_{1-3}$  - Holding N.O contact of contactor  $C_1$
- \* Contact  $C_{1-1}$  - auxiliary N.C contact of contactor  $C_1$ , initiates the braking process.
- \* Contact  $C_{1-2}$  - auxiliary N.C contact of motor contactor acts as an interlock preventing operation of brake contactor as long as motor contactor is closed.

Brake contactor  $C_2$  (with one N.C contacts).

- \* Contact  $C_{2-1}$  - auxiliary N.C contact of contactor  $C_2$ , acts as an interlock preventing operation of motor contactor as long as brake contactor is closed.

### Note:

There is electro mechanical interlock between  $C_1$  and  $C_2$ .

### Solbrake / SMB contacts

- \*  $C_a$  contact (Solbrake / SMB terminals 3-4 ), contact closes when Mains voltage is connected to Solbrake / SMB terminals and terminal 1-2 are open.
- \*  $C_b$  contact (Solbrake / SMB terminals 5-6), closes upon stop signal and contact terminals 1-2 closes after time delay  $t_1$ .

### Notes

- \* Motor contactor  $C_1$  cannot be operated when Mains voltage is not connected to terminals  $L_1$  and  $L_2$  (internal contact  $C_a$  in Solbrake / SMB, controlling motor contactor, closes after Mains voltage is connected and terminal 1-2 are open.
- \* When operating in Manual mode, DC injection will stop after time delay  $t_3$  as set on the Braking Time potentiometer.

## Operation

Upon start signal, as  $C_a$  is closed, motor contactor  $C_1$  closes, motor will operate and contact  $C_{1-1}$  opens.

Upon stop signal, motor contactor  $C_1$  opens, contact  $C_{1-1}$  closes and initiates the braking process.

Contact  $C_a$  opens, preventing motor contactor operation, and after time delay  $t_1$  contact  $C_b$  closes, closing the brake contactor  $C_2$ .

The yellow LED on Solbrake / SMB's front panel will light up indicating that brake contactor is closed.

After time delay of approx. 0.05 sec. DC current will be injected to motors' winding.

The yellow LED on Solbrake / SMB's front panel will light up indicating that braking current is now injected to the motor.

The DC injection will automatically cease when motor comes to a complete stop (when Automatic mode is selected) and the yellow LED turns off.

Contact  $C_a$  closes after time delay  $t_5$ , permitting motor restarting.

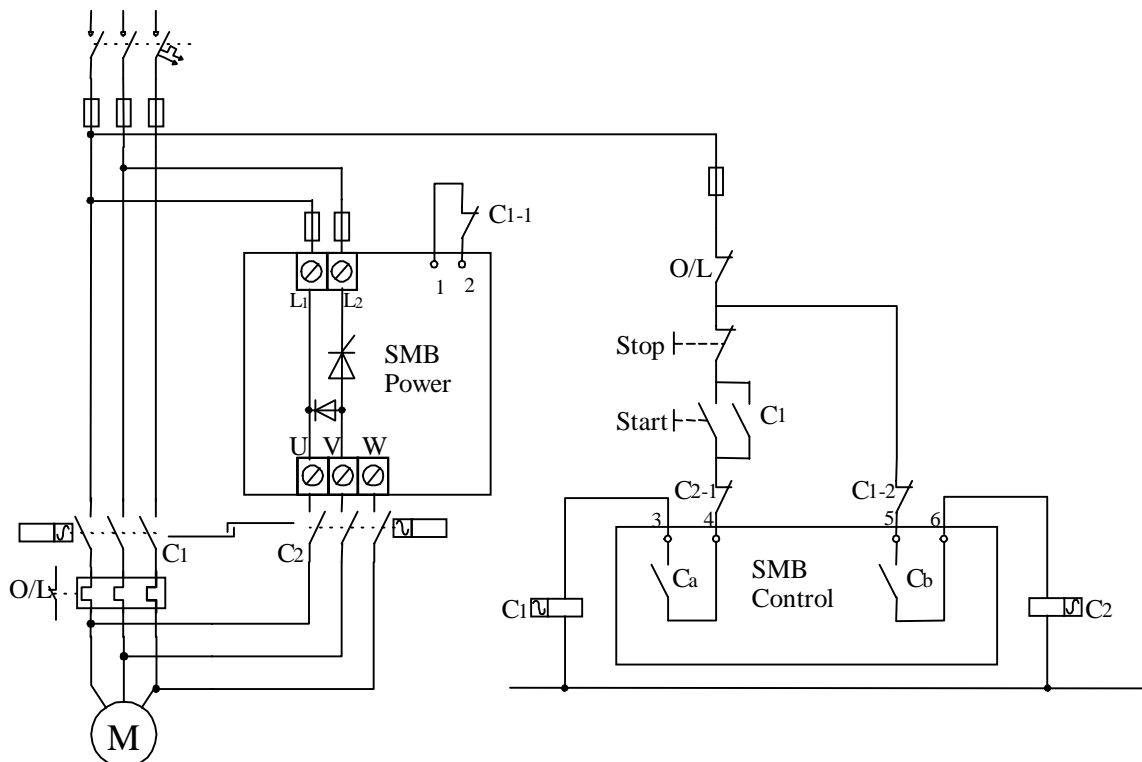

# Wiring & Operation

## Emergency Brake

A dedicated Emergency Stop button, with two contacts initiates braking.

When Stop contact is opened, contactor C<sub>1</sub> opens, the Solbrake / SMB is not initiated.

When Emergency Button is pressed, the Emergency Contact is opened and the N.O. contact of the Emergency Stop closes and initiates the braking process.

When Emergency Stop contact is opened, C<sub>1</sub> contactor opens and the Solbrake / SMB is operated, initiating the braking process.

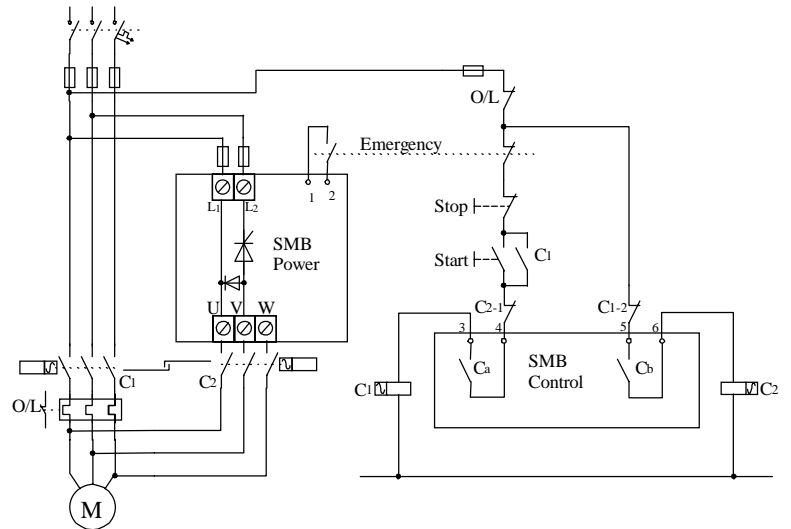

## Reversing

C<sub>2</sub> - SMB Contactor.  
C<sub>f</sub> - Forward Contactor  
C<sub>r</sub> - Reversing Contactor  
Interlocked Contactors.

Braking process is initiated when Contactors C<sub>f</sub> or C<sub>r</sub> open.

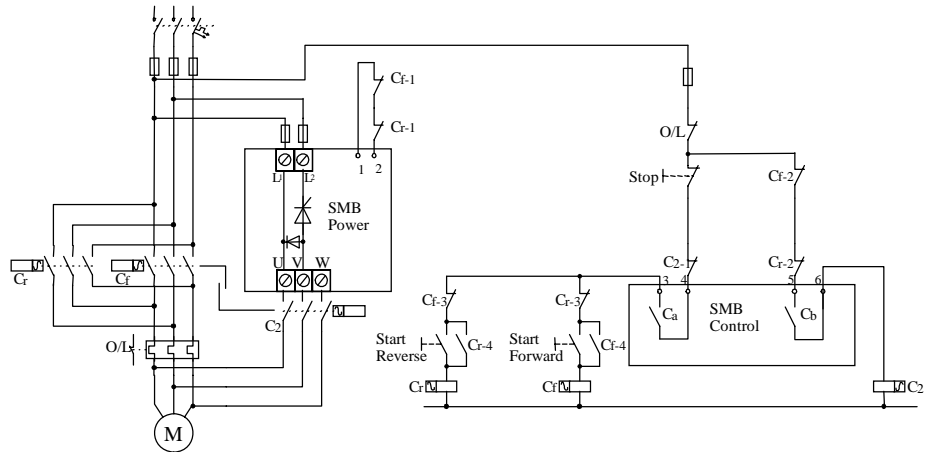

## Star-Delta

C<sub>b</sub> - SMB Contactor.  
C<sub>s</sub> - Star Contactor  
C<sub>d</sub> - Delta Contactor  
C<sub>l</sub> - Line Contactor  
T - Timer Relay

Braking process is initiated when Contactors C<sub>d</sub> or C<sub>l</sub> will open. Hence, a mechanical interlock between C<sub>b</sub> and C<sub>d</sub>+C<sub>l</sub> is recommended.

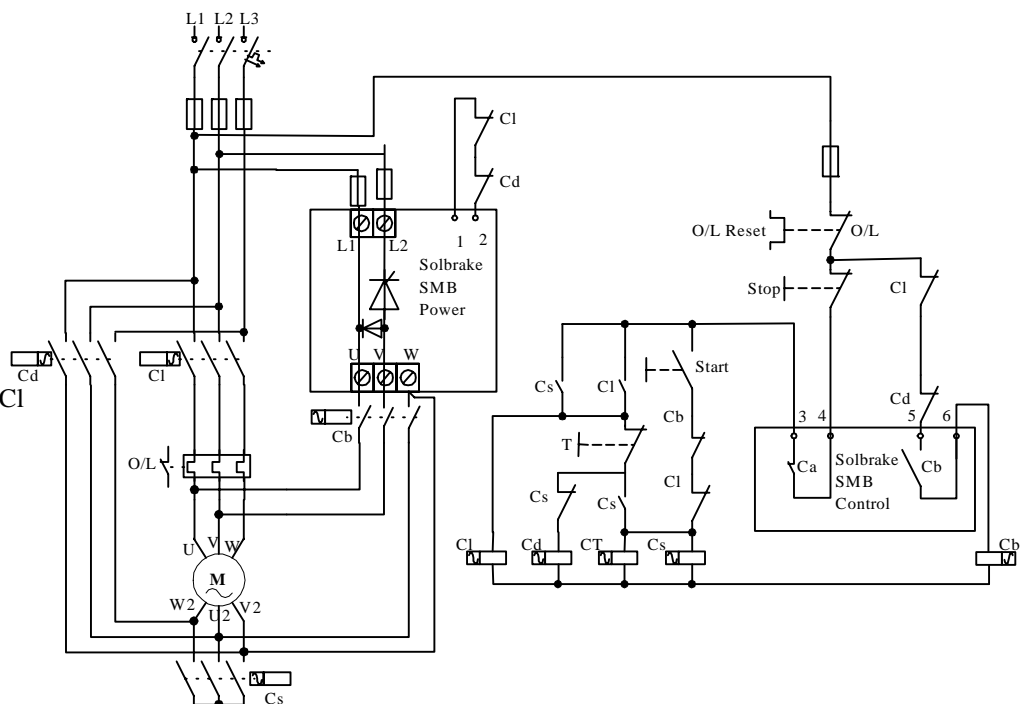

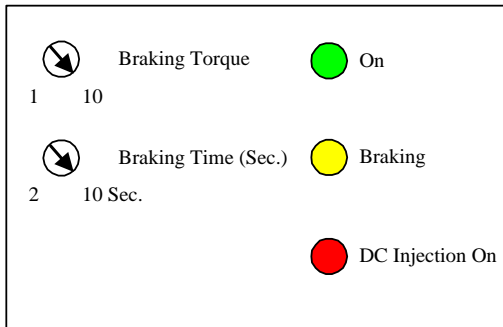

### Braking torque

Determines the value of DC current the Solbrake / SMB injects to the motor. The Solbrake / SMB can produce a braking current of up to four times motor's nominal current.

A too high setting may cause a fast stop and high mechanical shock. A too low setting may result in prolonged time until motor stops.

### Braking Time

\* **For Automatic Time-out** - The setting on the front panel determines the period of time during which the braking contactor is closed. DC current ceases automatically when the motor stops (Factory default internal Dip Switch setting) .

\* **For Manual Time-out** - The setting on the front panel determines the period of time during which DC current is injected to motor windings, regardless of when the motor stops (can be modified with the internal Dip Switch).

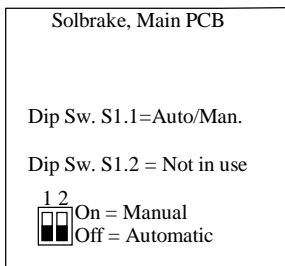

### LED Display

The Green LED indicates that power supply is connected to the Solbrake / SMB ( $L_1, L_2$ ).

The Yellow LED indicates that contactor  $C_2$  is closed. Motor restart is disabled when this LED is lit.

The yellow LED indicates that DC current is being injected in the motor windings.

During start-up the dip switch should be in the Off position for Automatic Time-Out.

1. Set Braking Torque to 5
2. Set Braking Time to 10
3. Start motor and wait until it reaches full speed.
4. Stop motor and check the braking procedure.
  - a) If braking has ceased and motor is still turning, increase braking Torque setting and try again.
  - b) If motor has stopped and the Yellow LED remains on, decrease Braking Time setting until the Yellow LED turns off shortly after the yellow LED has turned off.

**Note:** Set Braking Time potentiometer  $t_3$  to a slightly longer time than the time required for motor to come to a complete stop, even if the brake operates in an Automatic mode. This is required for two reasons:

1. Ensuring that even if the automatic time-out circuit did not sense that motor had stopped, the DC injection will cease shortly after motor stopped preventing excessive heating.
2. During time delay  $t_3$ , braking contactor remains closed even if the Automatic Time-Out circuit has stopped the DC current.

### Measuring the Braking Current

Approximate measurement of the braking current can be made with a true RMS ammeter.

### Trouble Shooting

1. Disconnect Mains voltage and check that contacts 3-4 and 5-6 are open.
2. Connect power to  $L_1$  and  $L_2$ . The green LED (On) should light up.
3. Check that contact between terminals 3-4 is closed.
4. Check that contact between terminals 5-6 is open.
5. Start the motor. Motor contactor should close. If it doesn't, check connection to contactor.
6. Press Stop button; motor contactor should open and brake contactor should close after a short time delay. Simultaneously the Braking Time and DC injection LEDs should be lit. If LEDs do not light up, check that auxiliary contact of Mains contactor connected between control terminals 1-2 is closed.



## Fuse Selection Table (400V)

### FUSE SELECTION (recommended values for mains supply of 400V)

SMB fuse value Title numbers in Amp's	Max. Thyristor I <sup>2</sup> t allowed	ALSTOM Ultra Fast Acting fuse	JEAN MULLER Semicon fuse links	FERRAZ / SHAUMAT Carbone Lorraine Protistor series	FERRAZ Specific Reference /Publication
Solbrake / SMB 8	400	GSGB30	500V - 40A	6,9 gRB17.63	G220967 / A600070
Solbrake / SMB 17	5000	GSGB55	500V - 50A	6,9 gRB17.63	G220967 / A600070
Solbrake / SMB 31					
Solbrake / SMB 58	18000	GSGB170	500V - 250A	6,6 URC 000 BS 88 180	C330144 / H600399
Solbrake / SMB 105	100000	GSGB350	500V - 350A	6,6 URD 2x000 BS 88 355	V330160 / H600399
Solbrake / SMB 210	600000	GSGB580	500V - 710A	6,6 URD 31 D 11 0630	Q300026 / D600188
Solbrake / SMB 310					
Solbrake / SMB 390	800000	GSGB800	500V - 1000A	6,6 URD 32 D 11 0800	W300192 / D600188

- Notes:
1. The above table is for maximum stop current of 400 % of FLC, maximum time of 30 sec and rated voltage of 400 V (see note 3 for exception).
  2. Rating may change with different external conditions such as ambient temperature, forced cooling etc. Refer to fuse manufacturer catalogs to confirm correct values.
  3. Ferraz ratings are **simulated** for 4xIn, 4 times per hour with a 10 sec. stop time for each stop.

# Technical Specification

---

## Solbrake 17A

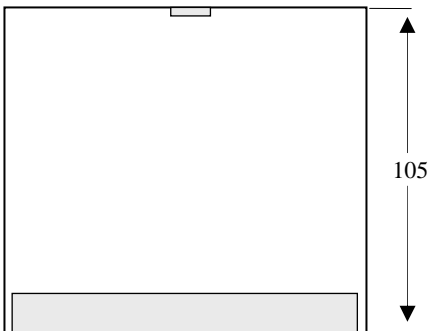
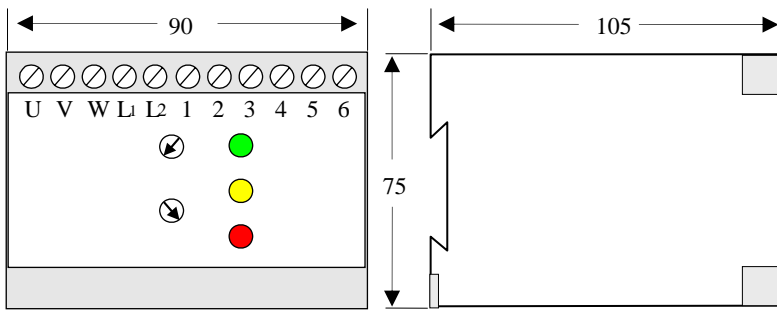

---

## Solbrake 31-58A

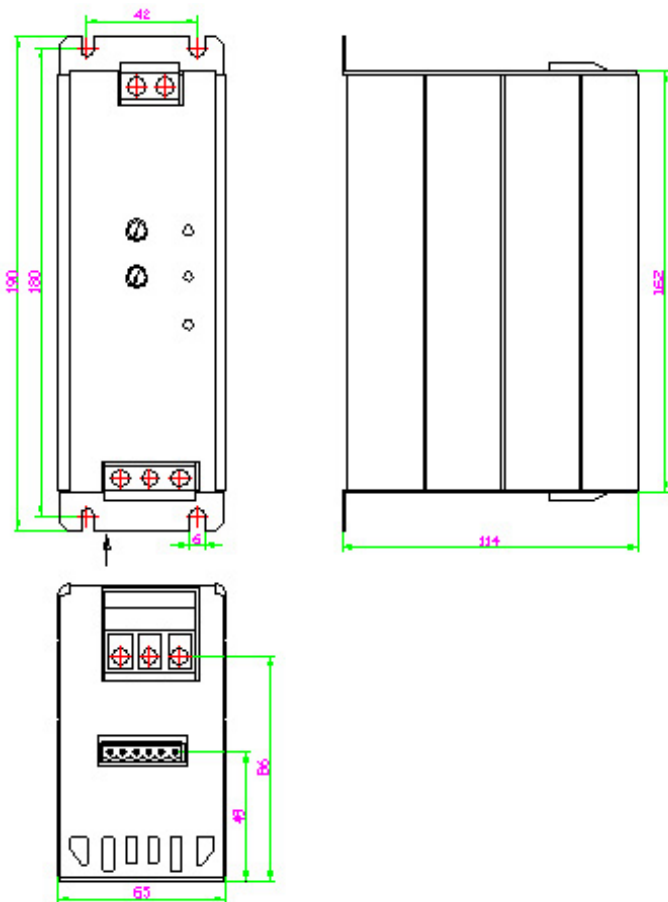

**Solbrake 105-210A**

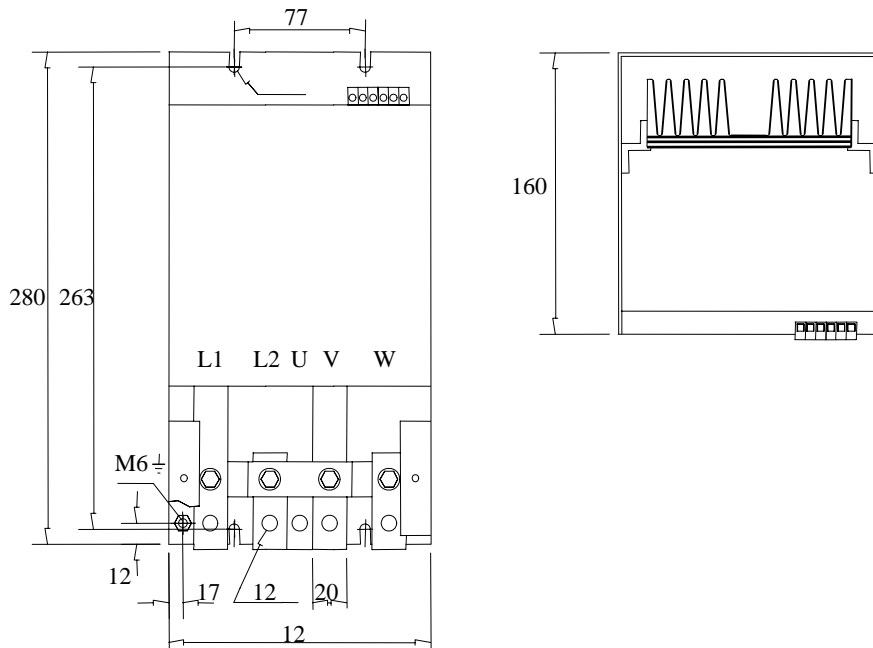

**Solbrake 310-390A**

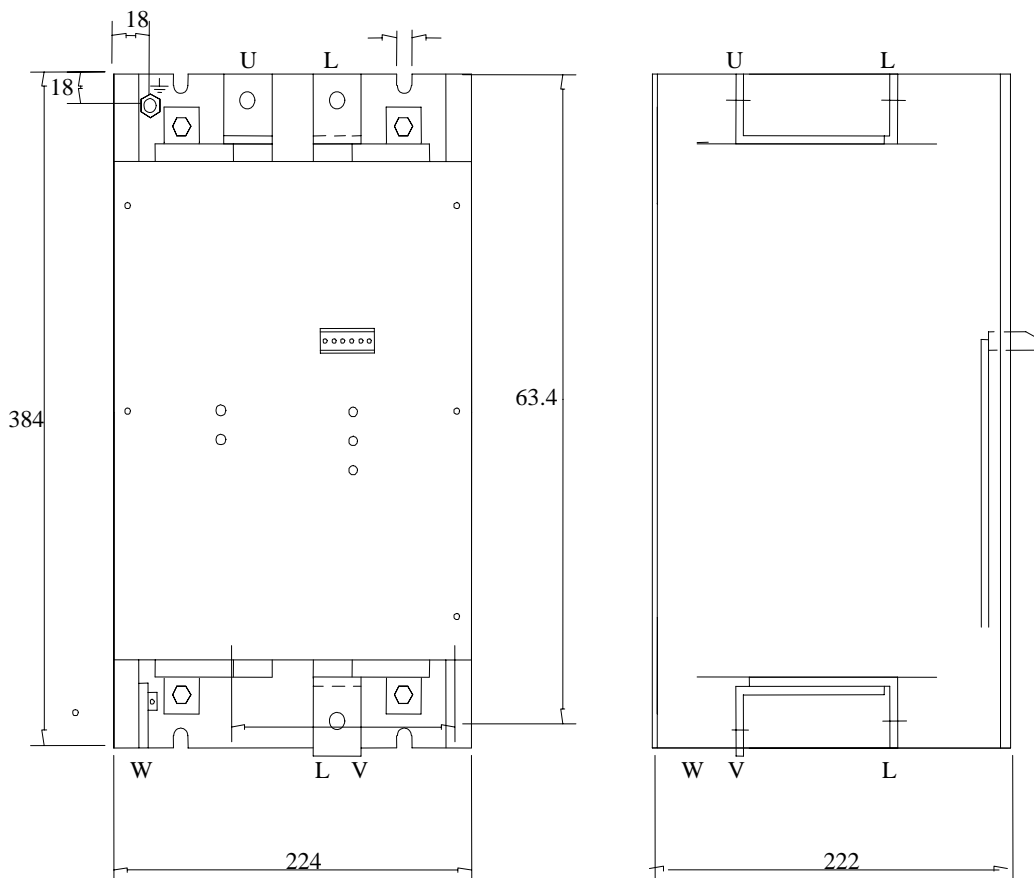

## Technical Specification

<b>Environment</b>		
Supply voltage	Two phase, line to line. 220-600VAC (690VAC for 210A – 390A)	+10% -15%
Frequency	50 / 60 Hz	
Load	Three-Phase, Three-Wire, Squirrel Cage Induction Motor	
Duty cycle	10% max.	10 sec. operation, 90 sec. rest
Degree of protection	IP 20 up to 58A (IP00 up to 390A)	
Altitude	1000 m above sea level	
<b>Adjustments</b>		
Braking current	1-10 for 0 - 4 times FLC	
Braking time	2-10 sec.	Optionally 1-30 sec.
<b>Protection</b>		
Automatic stopped motor sensor	Switches off the DC injection automatically when motor has come to a complete stop.	
<b>Indications</b>		
Indication lights (LEDs)	ON - Green	Illuminates when power is connected to SMB on L1 and L2.
	C2 closed – Yellow	Illuminates when contactor C2 is closed.
	DC Injection ON - Yellow	Illuminates when DC current is being injected to the motor windings.
<b>Temperatures</b>		
Operating	-10° to 50°C	
Storage	-20° to 70°C	
Relative humidity	93 % - non condensed	



Transdrive Engineering Services Ltd, Units 18 - 20 Moss Lane, Heyside, Royton, Oldham. OL2 6HR. England, UK

tel: +44 (0)1706 881940

fax: +44 (0)1706 882436

e-mail: [sales@transdrive.co.uk](mailto:sales@transdrive.co.uk)

website: [www.transdrive.co.uk](http://www.transdrive.co.uk)